



HAND CHAIN HOIST^{CE}

1/2 to 30 Metric Ton Capacity

FEATURES

- Safe and fool-proof operation with corrosion resistance features for long service life
- Lightweight and durable all steel construction with powder coated finish and plated frame components to resist corrosion
- Grade 80 Zinc plated alloy load chain used is manufactured in Germany, Austria or Japan
- Hand chain opening is formed with a radius for smooth operation
- Sealed ball bearings on the chain wheel maximize efficiency and serviceability
- Self adjusting double pawl disc type mechanical load brake insures positive load control
- Double roller guide insures load chain tracking
- Standard lift is 10 feet, Hand chain drop is 2 feet less than lift
- Meets: ASME/ANSI B30.16, OSHA, NASA-STD-8719.9 and EU Directives: 98/37/EC
- ATEX rated  II 3 GD IIA T4(X) for limited use in Hazardous Environments



OPTIONS

- Extended lifts
- Overload Protection (V) is slip clutch type

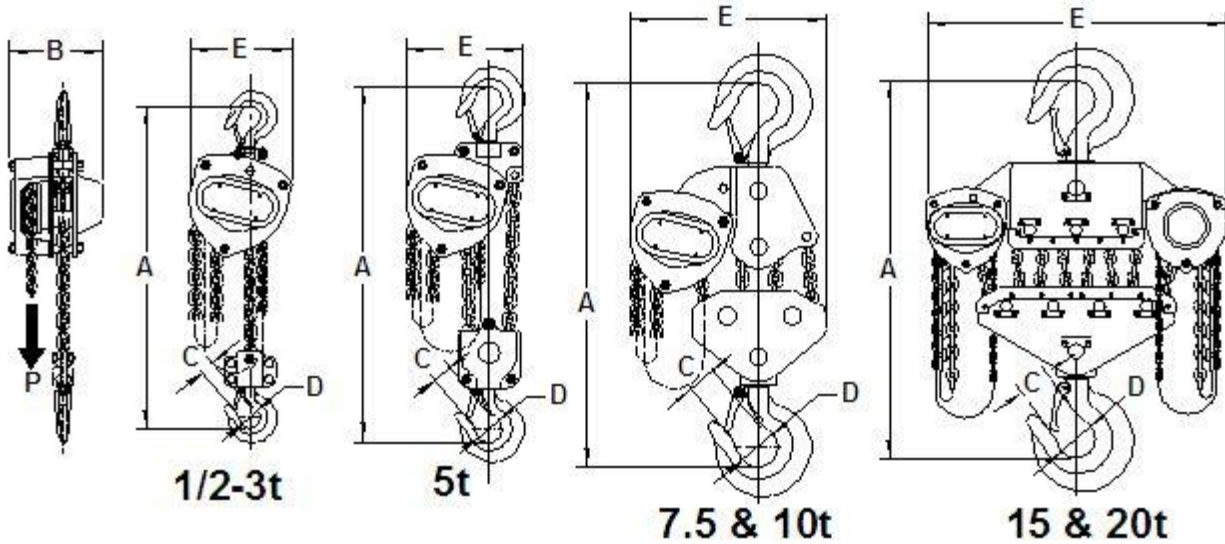

M SERIES SPECIFICATIONS and DIMENSIONS

(inches and pounds unless noted)

Base Model	Working Load Limit (WLL)	Fall	Chain (mm)	A" Min.	B"	C"	D"	E"	P (lbs) Max.	W (lbs) /Ft. lift	W (lbs) 10 Lift
M005	1/2t (1100 lbs)	1	5 x 15	13.6	5.2	0.91	1.24	5.8	54	0.74	21
M010	1t (2200 lbs)	1	6 x 18	14.8	5.9	1.06	1.50	6.8	56	0.92	27
M015	1.5t (3300 lbs)	1	7.1 x 21	17.4	6.8	1.30	1.70	7.7	60	1.12	37
M020	2t (4400 lbs)	1	8 x 24	18.5	6.9	1.38	1.80	8.3	75	1.30	43
M030	3t (6600 lbs)	1	10 x 28	21.6	8.1	1.57	2.00	10.0	84	1.88	71
M050	5t (11000 lbs)	2	9 x 27	27.1	7.4	1.77	2.10	11.0	81	2.88	91
M060	6t (13200 lbs)	3	9 x 27	27.2	7.9	1.85	2.64	17.0	65	4.13	136
M075	7.5t (16500 lbs)	3	9 x 27	27.2	7.9	1.85	2.64	17.0	85	4.13	136
M080	8T (16000 lbs)	3	9 x 27	27.2	7.9	1.85	2.64	17.0	81	4.13	136
M100	10t (22000 lbs)	4	9 x 27	30.1	7.4	2.13	2.95	18.2	85	5.38	167
M120	12t (26400 lbs)	6	9 x 27	35.4	7.9	2.80	3.74	28.3	68	8.26	298
M150	15t (33000 lbs)	6	9 x 27	35.4	7.9	2.80	3.74	28.3	85	8.26	298
M200	20t (44000 lbs)	8	9 x 27	37.4	7.9	3.23	4.17	33.1	86	10.76	423
M250	25t (55000 lbs)	10	9 x 27	38.5	7.9	3.23	4.17	38.2	87	13.26	473
M300	30t (66000 lbs)	12	10 x 30	52.0	17.1	3.23	4.17	27.2	105	15.76	772

Standard lift is 10 Ft. and standard hand chain drop is 2 Ft. less than lift. All hoists tested at Min. 125% WLL.

How to specify Model: Example M020-20-18V (2t Capacity, 20 Ft lift, 18 Ft. hand chain drop with overload protection)

Model -Lift -Drop Option

M020 -20 -18 V

V = With Overload protection